

Frame Installation

1. Place frame into net cooler opening.
2. Clamp top and bottom of frame into cooler opening (**Figures 1 & 3**).
3. Diagonal measurements must be within 1/8" of being equal before fastening top of frame (**Figure 2**). A frame out of square can result in door sag.
4. Check vertical and horizontal alignment with a level (**Figure 3**).
5. If necessary, loosen clamp and wedge from rear of frame with a screwdriver until sides are square. Hold in place with clamp. Fasten bottom, top and sides with No. 10 x 1 1/2" wood screws. Do not over tighten or distortion may occur. Caulk perimeter of frame on refrigerated side (**Figure 4**).

6. Wood adjoiner posts are used where two frames come together. Attach metal adjoiner strips after butting edge side of two frames and installing wood post. Metal strips are overlapped and then extended to butt against frame. Drive attachment screws through both metal pieces and into wood post. Caulk joints as required. **NOTE:** Some frames are ordered "flangeless". These frames will not have adjoiner posts.

Note:

The Ardco frame is designed to hold Ardco doors. The framing should not be used as support for the cooler header or to support any other type of construction.

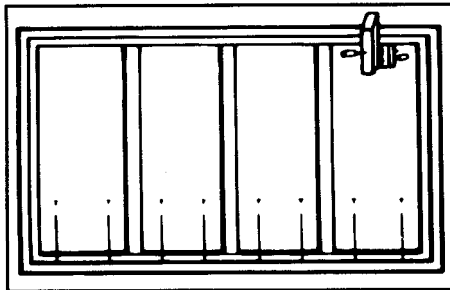

FIGURE 1

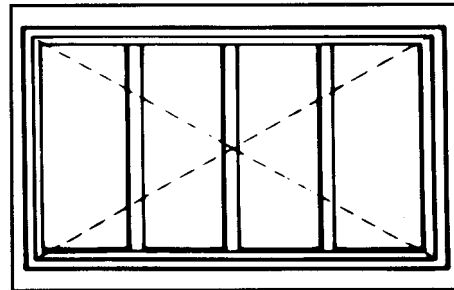

FIGURE 2

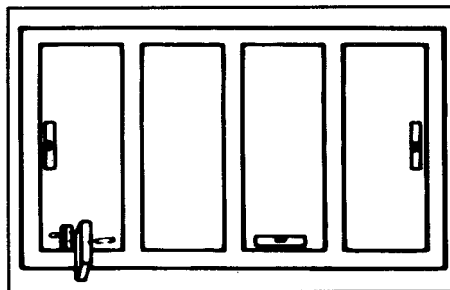

FIGURE 3

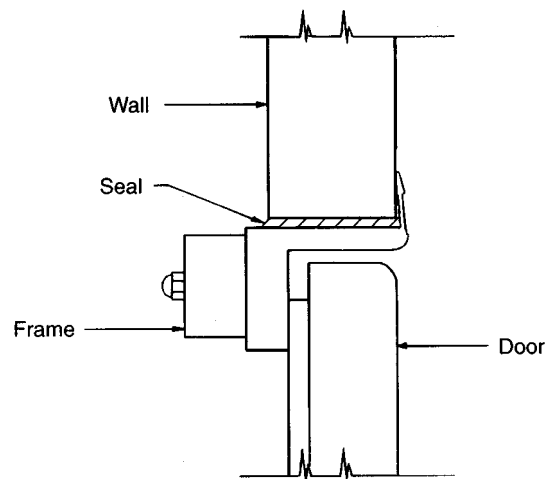

FIGURE 4

Door Installation

1. Lift door into frame to engage top door hinge pin into top hinge mounting plate (A).

2. Rest door on bottom hinge plate (B) which allows finger clearance to plug in electrical cord (C).

Note: M-Line and Enertech cooler doors are “No-Heat” doors. There will be no power cord on the door and no receptacle on the frame.

3. Open door to approximately 45° to align bottom door pin with mounting hole in bottom plate (B). Swing door open or closed to drop into proper position.

4. Adjust door closing tension with hex key tool furnished. Tool is a standard 5/16” allen wrench. If tool is lost another can be obtained locally. Insert tool into adjusting nut (NOTE: located in center-of-door recession, opposite electrical plug). Rotate tool only in direction door opens (towards the glass).

5. For left hand door adjustment, (see Figure 7). For right hand door adjustment, see Figure 8.

6. Select Lok Clip with proper thickness to fill space between top of door and outer frame (Figure 5).

7. Remove protective tape from doors and frame(s) before energizing unit for any extended period.

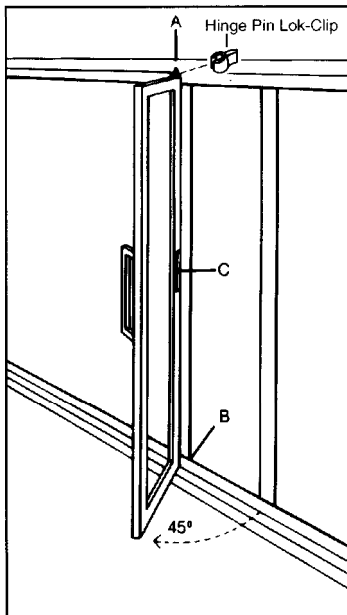

FIGURE 5

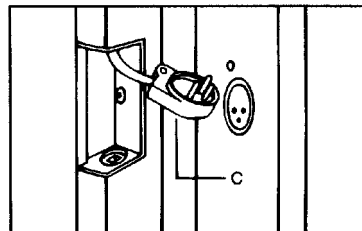

FIGURE 6

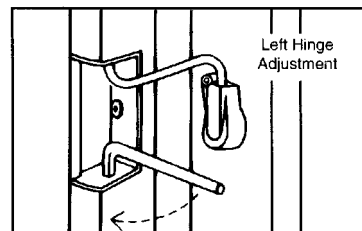

FIGURE 7

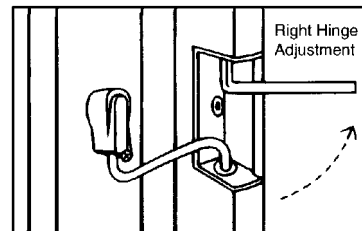

FIGURE 8

Important:

Proper size hinge pin Lok-Clip must be installed to prevent accidental disengagement of door.

Door Adjustment - All Models

1. After installation, if door appears to sag (**Figure 1**); Ardco's adjustable hinging features will allow this situation to be corrected.
2. Be sure the upper hinge mounting plate is aligned properly with the screw head centered on the gauge mark on the plate (**Figure 2**).
3. For proper alignment of the bottom mounting plates at the frame ends, the inboard screws should be flush with the end of the mounting plate (**Figure 3**).
4. For proper alignment of the bottom mounting plates at the mullions, both ends of the plate should be flush with both mounting plate screws (**Figure 4**).
5. To correct the problem in Figure 1, shift the top mounting plates to the left and the bottom mounting plates to the right.
6. To keep door in open position, open door fully and push Hold-open retainer. To release, close door (**Figure 5**). For Top Hold Open Doors, **see page 4**.

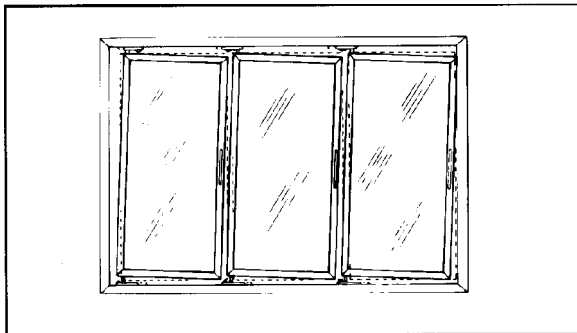

FIGURE 1

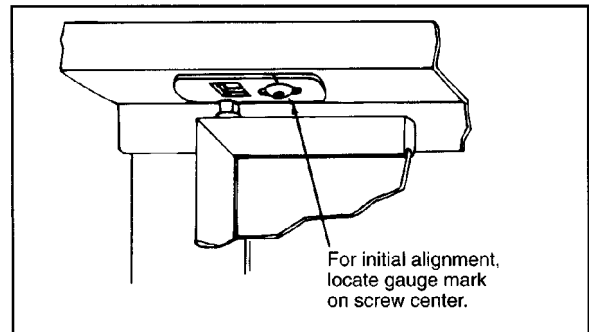

FIGURE 2

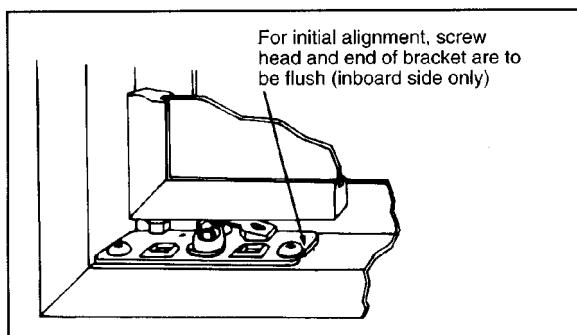

FIGURE 3

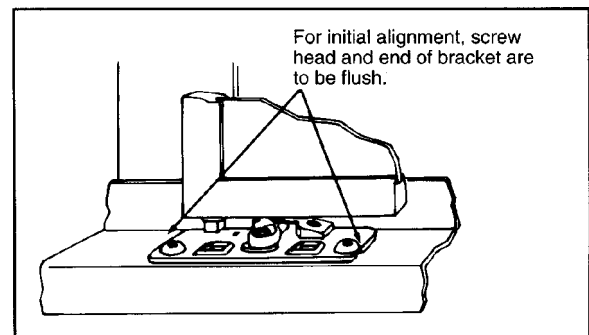

FIGURE 4

NOTE: A 5/32" allen wrench is supplied with the frame for adjustment, if needed.

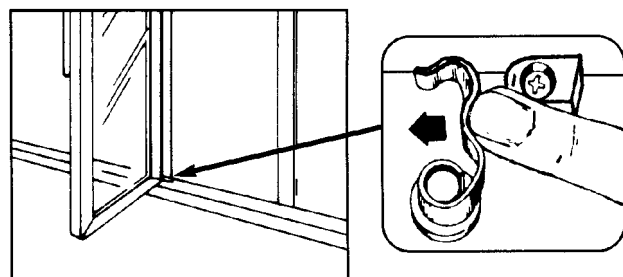

FIGURE 5

Hold Open Spring Installation - Top Hold Open Models

1. The connection of the hold open spring to the door is made after the door has been installed.

2. The assembly of the spring, washer, and shoulder screw is made at the factory. These parts are shown in **Figure 1**.

3. To install the spring onto the door, open the door to just before detent and place one side of the spring into the top groove of the pin on the door (**Figure 2**). Then apply pressure to the other side of the spring until it snaps into the pin.

4. To remove the spring from the door, open the door to just before detent and insert a screw driver between the legs of the hold open spring (**Figure 3**) and push it up until the spring is disconnected from the door.

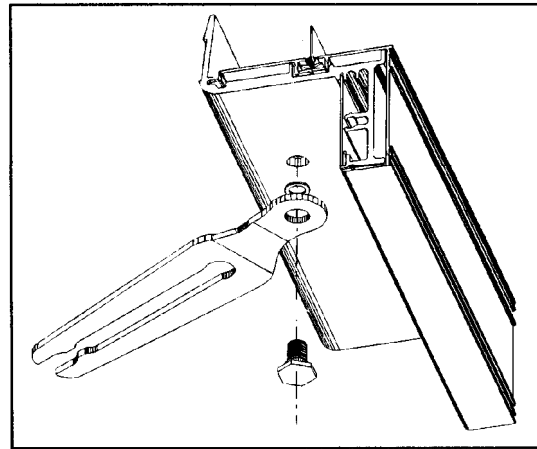

FIGURE 1

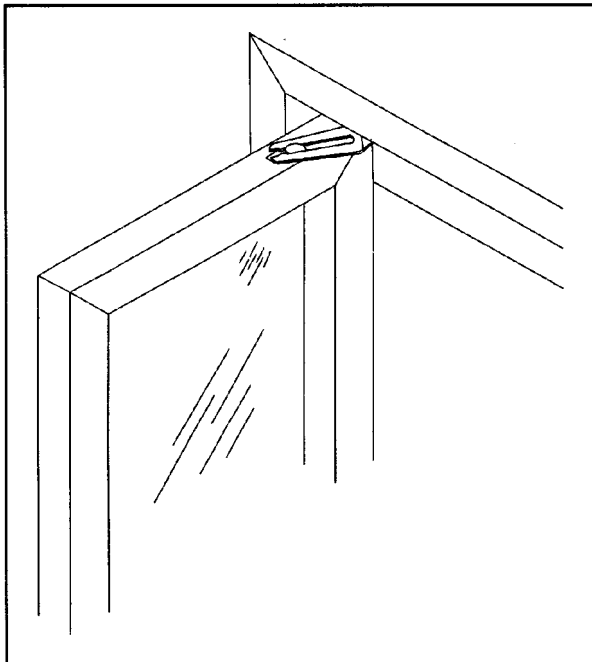

FIGURE 2

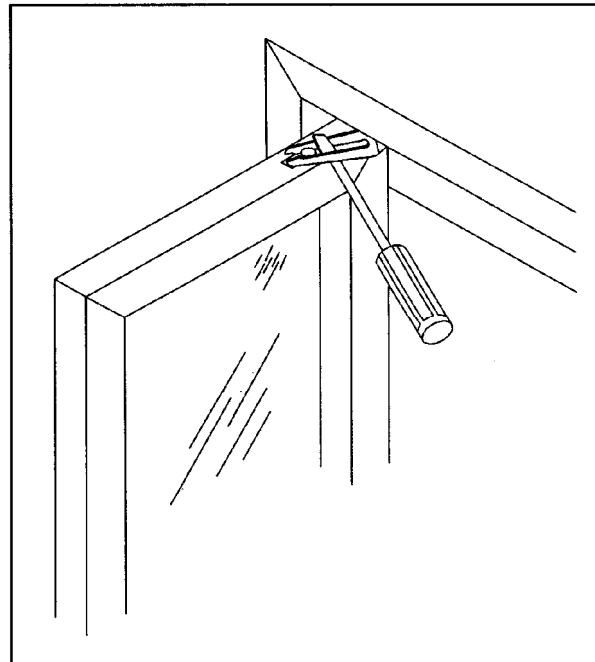

FIGURE 3

Swing Hinge Conversion - Bottom Hold Open Models

Frames (Figures 1 & 2)

1. Remove top hinge plate. Rotate plate 180° and install. Remove bottom hinge plate. Shift plate to right or left to correlate with swing conversion and reinstall hold open assembly on opposite end of mounting plate.
2. To accommodate power cord, rotate receptacle plate on mullion 180°. Transfer and electrical cap to unused receptacle.

NOTE: Enertech cooler doors are “No Heat” doors. There is no power cord on the door or receptacles on the frame.

Doors (Figure3)

1. Remove hinge pin Lok-clip from top of door.
2. Remove door strip plate from bottom of door. Install door stop plate at top of door. **NOTE:** Straight edge of door stop plate faces front of door.
3. Turn door upside down. Door is ready to install.
4. After installing doors in frame, replace all Lok-clips at top of door.

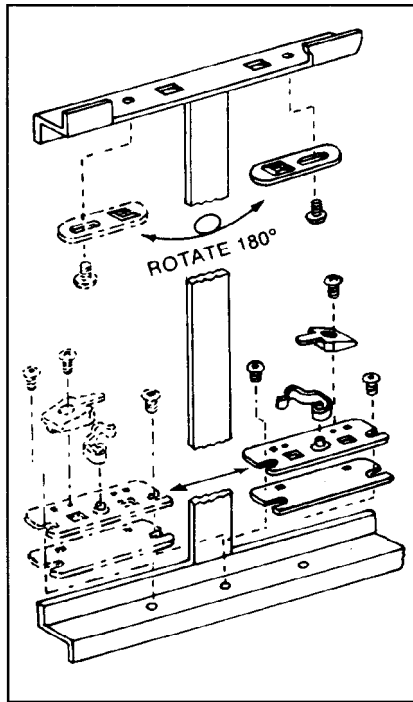

FIGURE 1

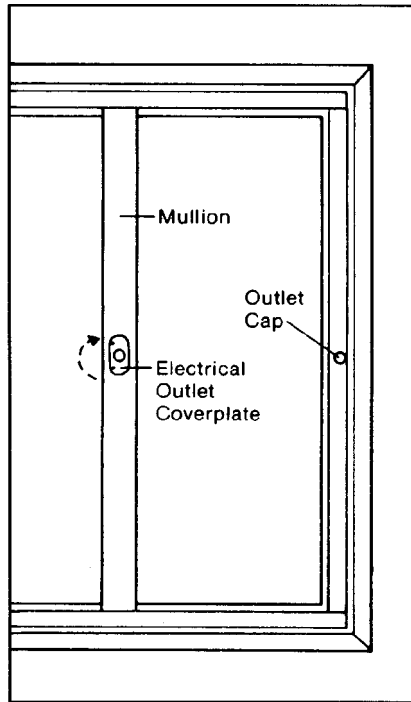

FIGURE 2

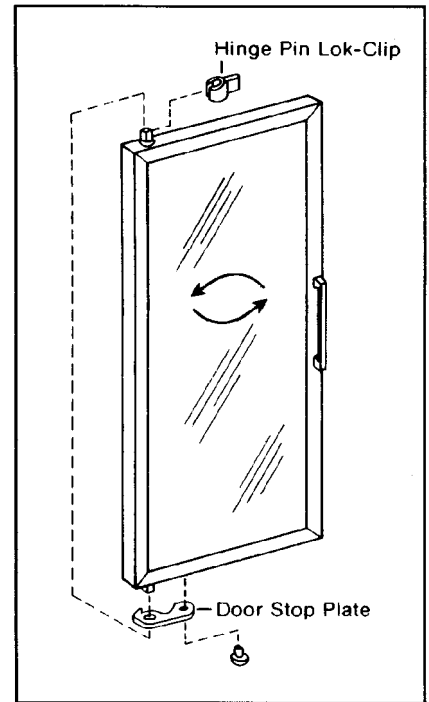

FIGURE 3

Swing Hinge Conversion - Top Hold Open Models

Frames (Figures 1 & 2)

1. Remove top hinge plate. Rotate plate 180° and reinstall on opposite side of the opening.
2. Remove the hold open spring and reinstall on the opposite side of the opening. Refer to page 4.
3. Remove the bottom mounting plate and reinstall on the opposite side of the opening.
4. To accommodate the power cord, rotate the receptacle plate 180°. Move the electrical cap to the opposite end of the frame.

NOTE: Enertech and M-Line cooler doors and frames may not have power cords.

Doors

1. Remove the hold open pin and screw from the top of the door and reinstall in the bottom of the door.
2. Move the door stop plate from the bottom of the door to the top.
3. Turn the door upside down and reinstall.

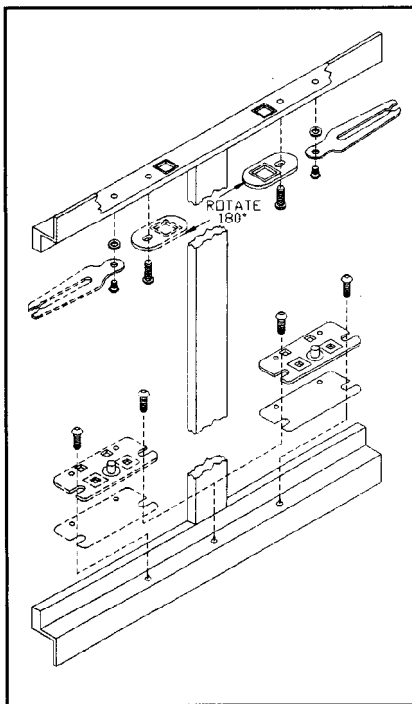

FIGURE 1

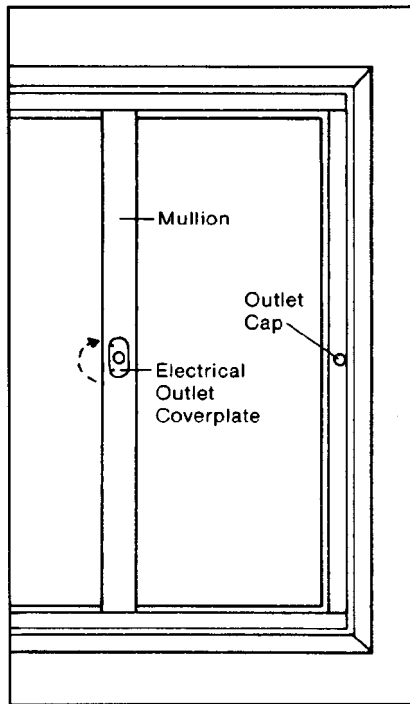

FIGURE 2

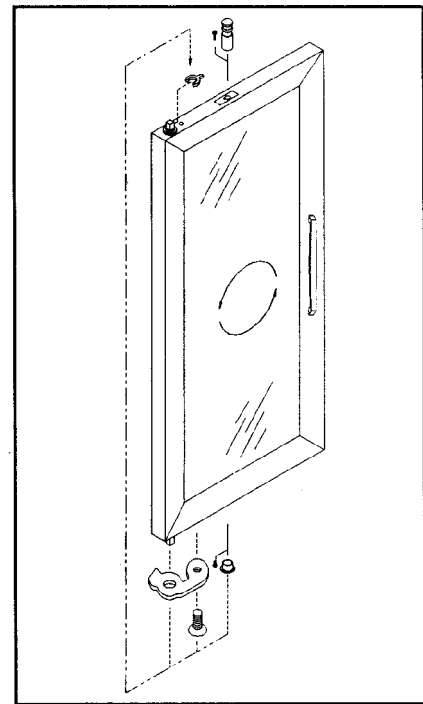

FIGURE 3

Lok-Shelf System Installation

1. Ardco shelving is secured to the frames by use of brackets that are preinstalled on Ardco frames and post clips that are on the front posts (**Figure 1**).
2. Place a front post at the end of the Ardco frame. Slide the post clips down the post into the post brackets (**Figure 2**).
3. The post clips are pre-crimped at the top of the tongue. After the post clips are installed in the brackets, crimp the bottom of the tongue to prevent accidental disengagement of the post clip (**Figure 3**).
4. Continue installing the front posts for the entire line-up.
5. For ease of shelf installation, Ardco supplies Post Stabilizer Bars. There will be four bars per frame. Starting at one end, install one bar at the top of the posts and one at the bottom of the posts. Then proceed to the first mullion and install the stabilizer bars on these posts (**Figure 4**).
6. Install the required shelves behind the first door, then proceed to the next door.
7. At this point, remove the stabilizer bars from the first mullion and move them to the posts at the second mullion. Continue this until you have the stabilizer bars on the end posts.
8. The shelves are installed into the slots on the rear of the posts (**Figure 5**).
9. Shelves may be leveled by using the leveler bolt at the bottom of each post.
10. Shelves may be placed at a slant by moving the rear mounting bar to a higher slot in the rear post (**Figure 6**).

NOTE: When the cooler or freezer sill is 5 1/2" deep or deeper, special mounting brackets will be required for the front posts.

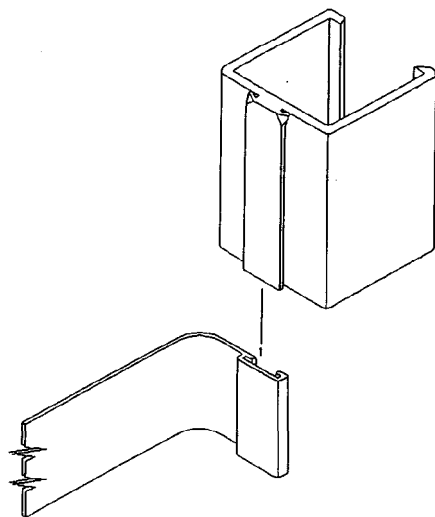

FIGURE 1

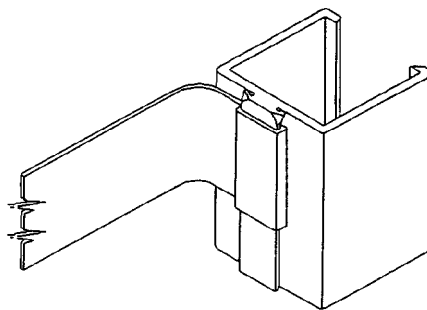

FIGURE 2

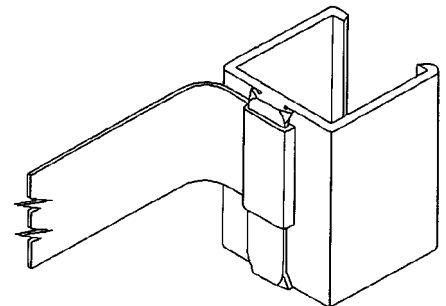

FIGURE 3

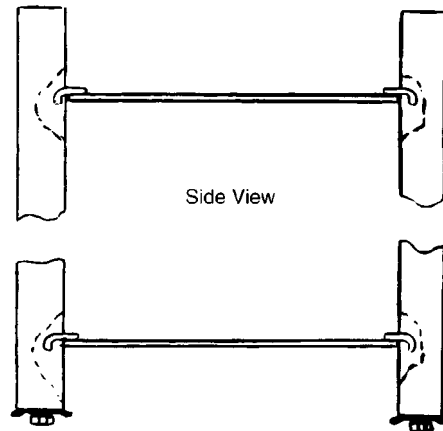
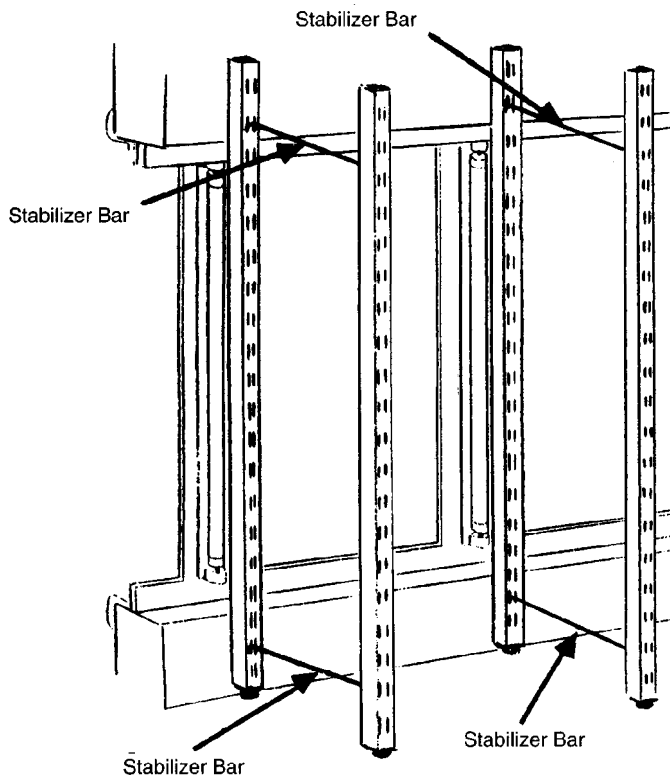

FIGURE 4

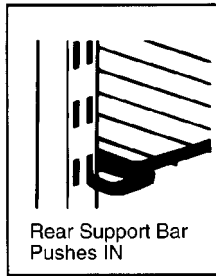
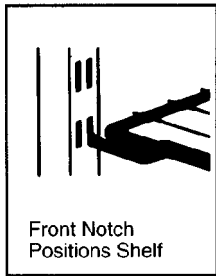

FIGURE 5

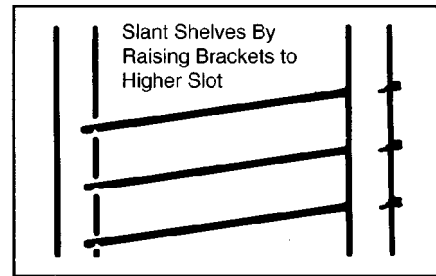
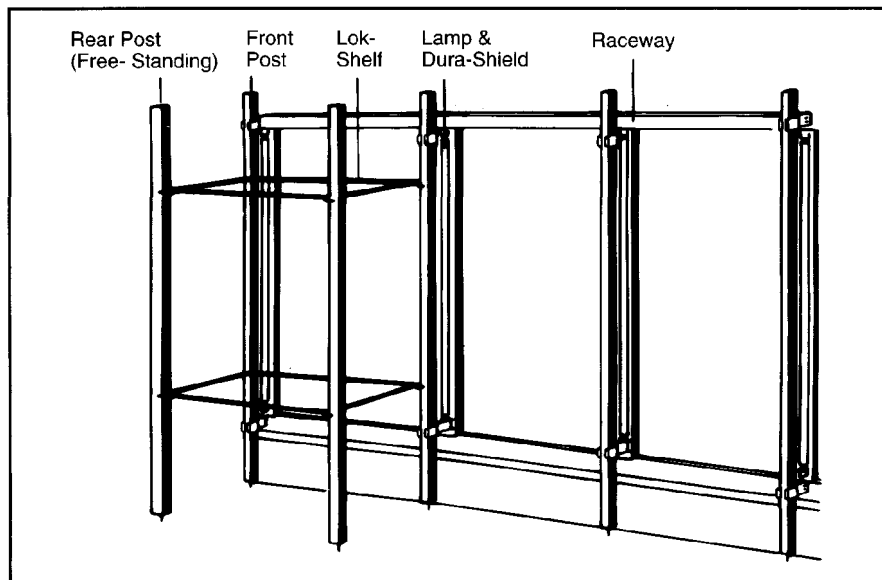

FIGURE 6



Electrical Hookup

1. After Ardco's frame (or frames) have been installed in the rough opening, bring the appropriate power to the back of the frame. Two circuits are recommended; one for the lights and one for the heaters, regardless of voltage.
2. The heaters are 120 volts on both the coolers and the freezers. The lights on the freezers are 120 volts. The lights on the coolers may be 120 volts or 220 volts. Check the requirements on the back of the frame.

3. All heater and light wiring in Ardco frames is labeled and color coded. **NOTE:** 208/230 volt wires are red. 120 volt wires are black and white.
4. An electrical box is shipped separately. This box may be attached to the frame; as illustrated below. Connections should be made in accordance with National Electrical Code and local codes that prevail.

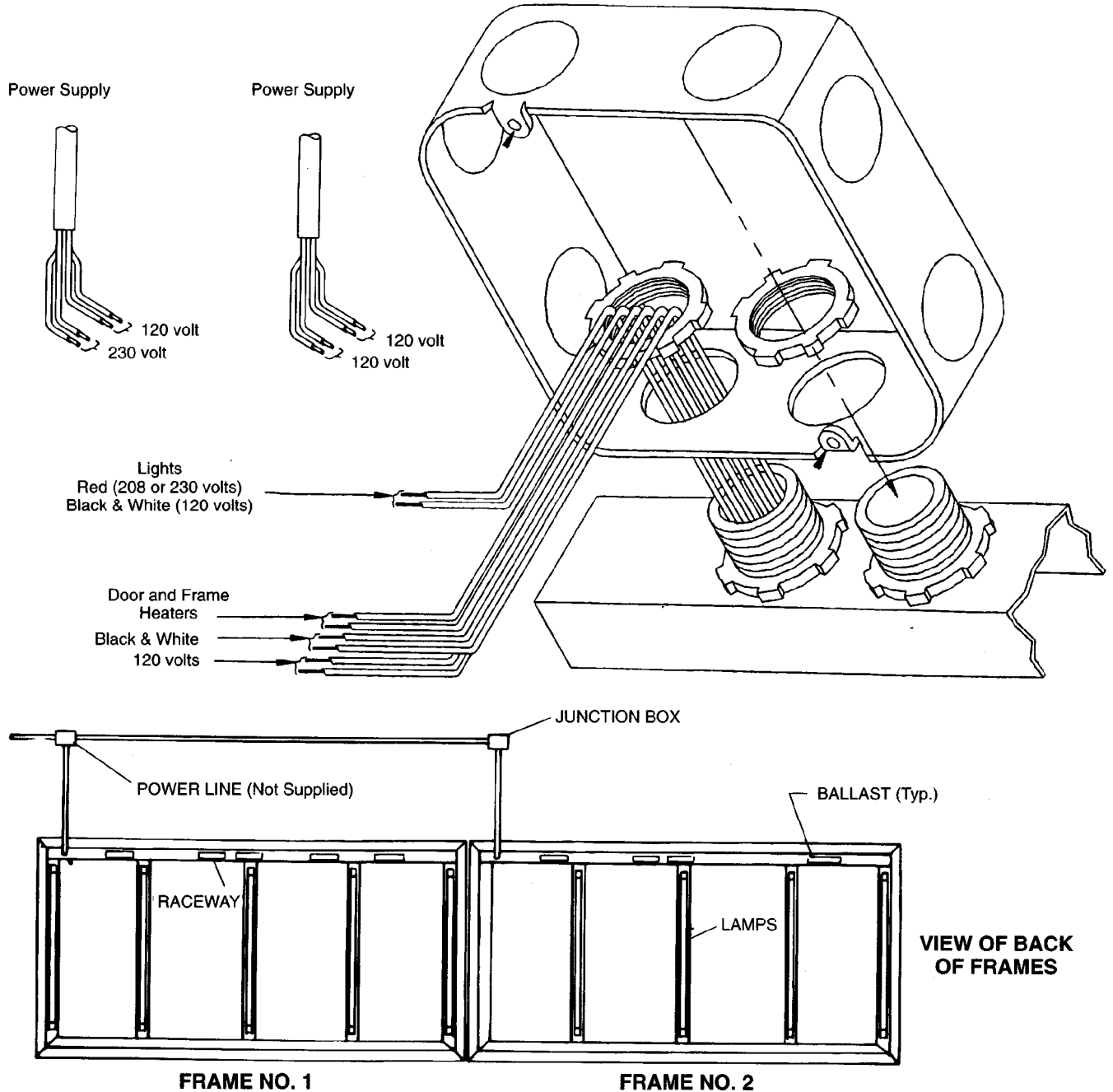

Trademarks/Patents

The following are trademarks of Ardco, Inc. and may not be used without permission.

Gildematic, Lektra Gard, Lok-Shelf System, MagniMatic, Speed Shelf, Sta-Clear 3, Swingline 180, Colorglide, Lektroni-Gard, Watt-Gard, Swingline II, Fast Track, Scan-X, Temper-Gard, Swingline 3, Enertech, TemperBent, Vanguard.

Ardco products are covered by the following patents:

U.S. Patents: No. 2,987,782; No. 3,131,421; No. 3,295,634; No. 3,343,506; No. 3,449,551; No. 3,475,594; No. 3,499,245; No. 3,508,361; No. 3,629,972; No. 3,837,119; No. 4,430,770; No. 4,641,461; No. 4,656,781; No. 4,691,486; No. 4,741,127 No. 753,043; No. 4,831,780; No. 4,852,303.

British Patents: No. 1,175,336; No. 1,553,751.

Canada Patents: No. 642,937; No. 874,486; No. 1,083,690; No. 1,171,209; No. 1,169,909.

International Patents: No. 1,1065,813; No. 3,696,360.

Sweden Patents: No. 7705904-6.

Argentina Patents: No. 149433.

Denmark Patents: No. 1333/81; No. 2177/77.

Norway Patents: No. 810996; No. 771760.

European Patents: No. 82.111346.1; No. 81.102173.2.

Holland Patents: No. 77.06262.

Italy Patents: No. 1079851; 48245-A/78.

Australian Patents: No. 511762; No. 527 447; S/N 66038/81; S/N 83,553/82; S/N 85554/82.

Belgium Patents: No. 856120.

France Patents: No. 7718355.

Germany Patents: No. P.2722410.8; No. G.7715757.4.